

Inventory Information Management System Using The Lifo Method Based On Multiuser At The Fara Collection Store Karangawen

Uswatun Khasanah

¹ Study Program System Computers - College of Electronics and Computers (STEKOM),

Jl. Majapahit 605, Semarang, tel/ fax : (024) 6723456

haris.ihsanil.huda@gmail.com

Abstract: Fara Collection shop sells various shoes and sandals for fulfil need public . The business processes carried out by the Fara Collection Store are still ongoing use recording manually where the transaction is purchasing , recording inventory , and record keeping sale shoes and sandals are noted in book . Recording manually felt not enough effective and efficient and also results in the preparation process report supply become more complicated . The purpose of study This is For develop system information supply goods use LIFO method where units are sold is the last unit come in , so makes it easier arrangement goods Good That enter nor take goods , and goods will fast sold Because follow the trend with the latest models that produce profit more big and system This is also equipped with minimum stock limit report aims know the minimum stock limit for goods so that can do announcement up to date regarding out of stock items . In research this , system built use method used writer is method research and development or Research & Development (R&D) with 6 stages namely research and information collecting, planning, developing preliminary form of product, preliminary field testing, main product revision, main field testing from Borg & Gall (1983). Output from system This is report management consisting of from user report , report goods , supplier reports , reports customer , report purchases , reports sales , reports Minimum stock , report LIFO inventory . With apply system This is expected user more easy in running business processes . Software that the author use is Microsoft Visual Basic 6.0 with SQL Server 2000 database.

Keywords : System Information , Inventory , LIFO Method, Microsoft Visual Basic 6.0..

1. INTRODUCTION

The development of computer technology is currently developing very rapidly, this allows users to obtain fast and accurate information. The presentation of fast and accurate information is increasingly needed by various parties, so a medium is needed that can present this information, namely computers. A computer is a tool for processing information according to procedures that have been formulated. A better term for the broad meaning of computer is information processor or information processing system (Ervan, 2014).

One of the uses of information systems in companies is in the warehouse section which manages inventory. Meanwhile, inventory of goods is goods purchased, produced, owned by the company which will be resold as a normal activity or activities of the company (Sugiono, 2009). One method of inventory is the *Last In First Out method* . The *Last In First Out (LIFO)* method means that the last item entered (purchased) will be the first item to leave (sold) (Hermanwan, 2008). So that management performance runs well, it is necessary to implement a computerized system using a *multiuser network* . *Multiuser* is an operating system that can be run by more than one user simultaneously (Edy and Jurike, 2014).

Fara Collection Karangawen Shop is a shop that sells school equipment including shoes and sandals which is located at Jl. Semarang – Purwodadi No.92, Waruk , Karangawen , Regency Demak , founded in 2011. Based on information from interviews conducted, the inventory system procedure at the Fara Collection Karangawen Store has been very simple, using book recording, starting from the warehouse section checking the goods in the warehouse, then the warehouse section will record stock on a piece of card stock. The stock data is reported to the admin section as a report. The admin section will recap and submit the report to the leadership. Based on this report, the process of purchasing goods from *the supplier will be carried out* . When the goods are sent by *the supplier* and handed over to the Fara Collection Karangawen Store, the warehouse department receives the goods along with a note from *the supplier* . Next, the warehouse department will match the arriving goods with the purchase receipt. After all the items have been *checked* and match the purchase receipt, the admin section will record and recapitulate all purchase receipts into a book, then archive them as a purchase report and submit to the management.

The following is an example of data on goods entering and leaving the warehouse at the Fara Collection Karangawen Store in the April 2019 period:

Table 1.1 Goods Inventory Data for the April 2019 Period

No	Name of goods	Last Month's Stock	Purchase	Sale	Last stock
1	New Era Rebecca 808 – H/H	3	50	40	12
2	New Era New NBA 02 – Black	5	55	20	40
3	Trekkers SL-Comic – White	4	30	4	30
4	New Era King– Black	0	20	20	0
5	Kodachi B116 – Blue/Silver	6	0	3	3
6	Ardiles BB – Navy	2	60	55	6
7	Canvas – Blue	4	40	32	12
8	Trekkers TA-Neo – Black/White	1	30	31	0
9	New Era Tuscany – HP/Fushia	10	0	1	9
10	Rionella Gabby 06 – Merah	0	100	25	76
11	Ardiles WRG-Usy – Navy	2	50	20	32
12	AOD Advanture Pharsa – Navy	6	0	4	2
13	Carvil Julio M – Black	4	35	9	30
14	Ornella MR 668 – Coklat/Krem	5	25	3	27
15	Ornella MR 582 – Moka	3	40	30	12
16	Homy ped Linzy-N – Coklat	6	0	5	1
17	Homy ped Sakura – Marun	1	15	15	1
18	Rullief FFC 707 – Tan	15	0	3	12
19	Esterlie RJ 204 – Kopi	2	100	86	16
20	Ando – Black	0	70	60	10

Source: Fara Collection Karangawen Store

The inventory problem that arises at the Fara Collection Karangawen store is that the data processing process and inventory reports have not been computerized, that is, they are recorded in books. Then, when recording inventory, goods are in the form of stock cards so that data security is vulnerable to being changed or manipulated. The recording and calculation of goods entering and exiting the warehouse is inaccurate because the calculations are still done manually. Apart from that, the shop only makes purchases of goods that are really low or even out of stock. This causes delays in ordering goods from *suppliers* because there is no notification regarding the minimum stock of goods, making it difficult to control the purchase of goods.

2. THEORETICAL FOUNDATION

2.1. Computer

computer is processor information or system processor information (Ervan, 2014).

2.2. System

System is something network consisting of from various mutual elements interact For reach something purpose (Mahatmyo , 2014).

2.3. Information

Information is data that has been organized and has been own uses and benefits (Krismiaji , 2015).

2.4. System Information

System information is A Suite a formal procedure by which data is grouped , processed become information , and distributed to users (Kadir, 2014).

2.5. Inventory

Inventory of goods is goods purchased, produced, owned by a company that will be resold as a company activity (Sugiono, 2009).

2.6. LIFO Method

The Last In First Out (LIFO) method means that the last item entered (purchased) will be the first item to leave (sold) (Hermanwan , 2008).

2.7. R&D

Understanding Research and Development (R&D) is a development research procedure which basically consists of two main objectives, namely: (1) developing the product, and (2) testing the effectiveness of the product in achieving the objectives (Borg & Gall, 1983) .

2.8. Prototype

P rototype is version from system potential that provides developers and *users* with something description about How system in form its perfect will functioning (Yulia and Dewi, 2015) .

2.9. Flow Of Document

A bunch symbols that show or describe Suite program activities from beginning until end ,*flowchart* used For describe order steps a job at something algorithm (Jacob, 2012).

2.10. Data Flow Diagrams

Tool for create comprehensive diagrams To use . *Data flow diagram* (DFD) consists from notation data storage (*data store*), process (*process*), data flow (*data flow*), and source input (*entity*) (Jakub, 2012).

2.11. Normalization

One of method approach used in build relation database design with apply a number rule . (Jacob, 2012).

2.12. Entity Relationship Diagrams

Entity relationship diagrams (ERD) also describe the relationship between one entity that has a number of attributes and other entities (Fathansyah, 2015).

2.13. Database (Database)

Databases is mutual data sets *relate* between data one with other stored data in One savings outside computer and need something device soft certain For manipulate it (Jogyanto , 2011).

2.14. SQL Server 2000

SQL Server 2000 is one of them product *Microsoft* is quite powerful. (Fauzi and Amin, 2012).

2.15. Microsoft Visual Basic

Microsoft Visual Basic is A Language programming that offers *Integrated Development Environment* (IDE) (Stefano, 2014).

2.16. Multiuser

Multiuser is system possible operations run by more from One user in a way simultaneously . (Edy and Jurike , 2014) .

3. METHODOLOGY

Methods are one of the important factors in the process of preparing a thesis and are also something method in develop as well as test truth from something knowledge knowledge .

Methods data collection as following :

- **Observation Method**
That is search and collect data with method observe in a way direct the reality on the ground , then processed in form report .
- **Interview Method**
Search and collect data with method do discussion direct with supervisors (instructors) in the field nor with other parties can help in preparation report This .
- **Documentation Method**
Methods of searching and collecting data with method read document as well as the expected service manual become instruction main in preparation report This .
- **Literary Method**
That is search and collect data with method take from books , brochures , catalogs , etc book other related knowledge with topic to be discussed .

3.1. Research Materials

- *Software and Hardware*
 - *Software*
System operation *Microsoft Windows 7 Ultimate*. Product design *Microsoft Visual Basic 6.0*. Databases *SQL Server 2000*.
 - *Hardware*
3 units computer . *Processor* : Intel Core i3-2370M CPU
Memory : 2 GB
Hard disk : 500 GB
Monitors : 14 Inc
1 Printer unit, *Optima 3D mouse*.
- *Input data* consists from : User, Goods, *Supplier*, Customer Data Form .
- *Transaction Process* : Purchase and sale .
- *Report Data Output* consists from : Reports on User Data, Goods, *Suppliers*, Customer Data , Purchases , Sales , Minimum Stock, LIFO Inventory .

3.2. Flow of Documents

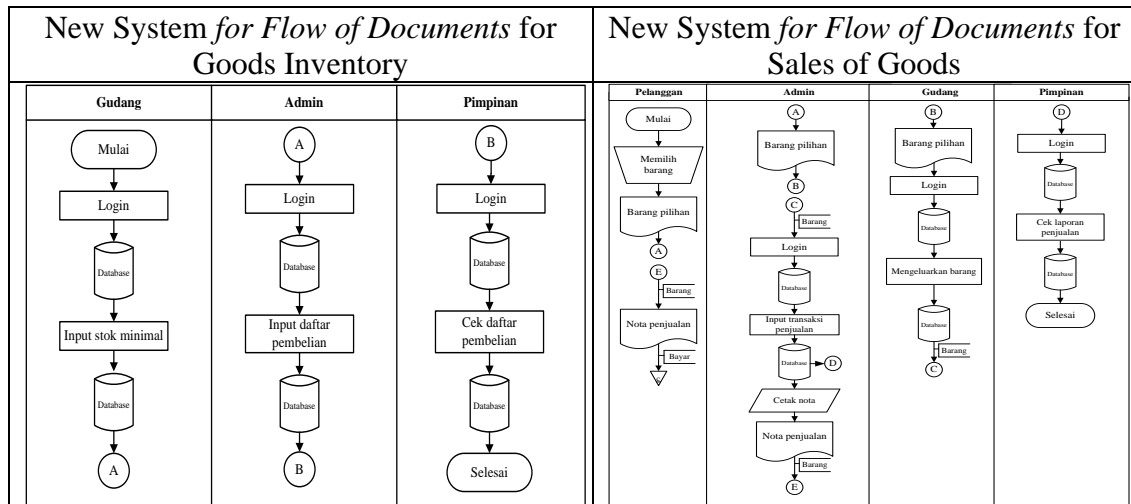

3.3. Context Diagrams

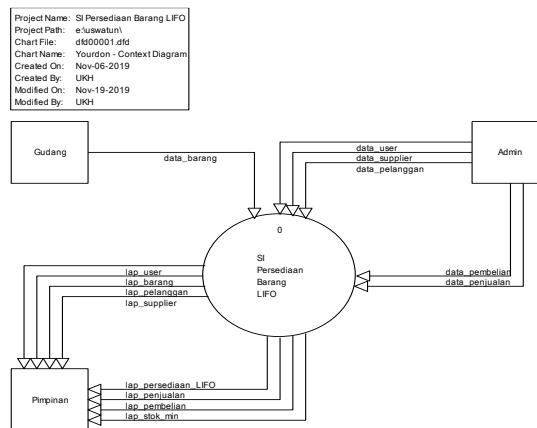

3.4. Decomposition

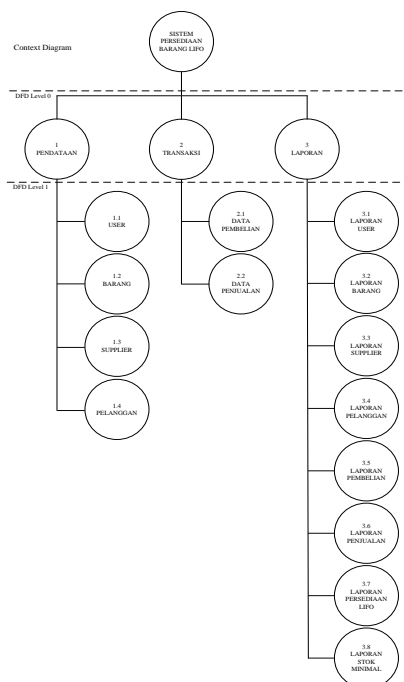

4. RESULTS AND DISCUSSION

4.1. Login Form Display

4.2. Main Menu Form Display



4.3. Display Access Rights Form

Grup	Data Barang	Data Supplier	Data pelanggan	Pembelian	Penjualan	Lap. Barang	Lap. Supplier	Lap. Pelanggan	La
Admin	Tidak	Ada akses	Ada akses	Ada akses	Ada akses	Tidak	Ada akses	Ada akses	Da
Revisi	Ada akses	Tidak	Tidak	Tidak	Tidak	Ada akses	Tidak	Tidak	Ta
Revisi	Tidak	Tidak	Tidak	Tidak	Tidak	Ada akses	Ada akses	Ada akses	Da

4.4. User Data Form Display

KODE USER	NAMA USER	GRUP
01	Uswatun	Admin
02	Re	Penjualan
03	Agri	Revisi

4.5. Display of Goods Data Form

KODE BARANG	NAMA BARANG	HARGA BELI	HARGA JUAL	KATEGORI	GOLONGAN	LOKASI	STOK MINIMAL
SP-001	New Era Bebecca 000 - B/H	90000	110000	Sepatu	Anak	Bak - 1	2
SP-001	Emmy ped SS - Hitam	60000	70000	Sandal	Anak	Bak - 1	2
SP-002	Tekdori Lampu - Putih	10000	90000	Sepatu	Anak	Bak - 1	2
SP-002	Andalis 00 - Grey	100000	120000	Sepatu	Bewas	Bak - 2	2
SP-004	Kantus - Putih	10000	90000	Sepatu	Bewas	Bak - 2	2
SP-005	Ballad PVC 00 - Tan	90000	100000	Sandal	Bewas	Bak - 2	2

4.6. Display Supplier Data Form

KODE SUPPLIER	NAMA SUPPLIER	ALAMAT	NO TELPON	TANGGAL MASUK
SP-001	Ahmad	J.Lingkar Barat Kadus	08208427545	01/01/2014
SP-002	PT. Al Java	Jl. Agung No 4 Kadus	08212106039	09/07/2015
SP-003	Toko Sepatu any	Jl.Mulia Raya No.90 Jakarta	08011222939	25/06/2016
SP-004	Sinar	Jl.Sugak No 0 Jakarta Utara	07125214477	05/06/2017
SP-005	Maja	Jl.Nembung Timur Semarang	06111130223	16/06/2016

4.7. Display Customer Data Form

KODE PELANGGAN	NAMA PELANGGAN	ALAMAT	NO TELPON
PS-001	Ahmad	Karangawen	06155642211
PS-002	Ana Kartina	Karangawen	08999022144
PS-003	Ayu Dewi	Karangawen	08256683399
PS-004	Rara Ajib	Karangawen	08208736351
PS-005	Eva Milya	Wringgati	0827470906

4.8. Display Purchase Data Transaction Form

KODE BARANG	NAMA BARANG	HARGA BELI	BIYAK	SUB TOTAL
SP-001	New Era Bebecca 000 - B/H	90000	0	360000

Total: 360000

4.9. Display Sales Data Transaction Form

FARA COLLECTION Selasa 3 Maret 2020 10:16:10
 Form Input Data Barang Penjualan
 Menu ini digunakan untuk melakukan penginputan dan update data penjualan

Nota NT000001 Tanggal 01/03/2020 Pelanggan PL-001 Akun

Data Barang
 Nama Barang [Dropdown] Jumlah Keluar 0 Sisa 0
 Harga 0 Stok 0 [Tambah]

KODE BARANG	NAMA BARANG	HARGA BARANG	BANYAK	SUB TOTAL
SD-002	Rutilief FFC 707 - Tan	108000	1	108000

Baru Simpan Batal Koreksi Hapus Kembali Cetak

Total Bayar 108000
 Bayar 110000
 Kembali 2000
 User 01

4.10. the Goods Data Report Form

FARA COLLECTION
 Laporan Data Barang
 Menu ini digunakan untuk melihat data barang

Semua Per Kode Barang

Nama Barang [Dropdown]
 Kode Barang [Dropdown]

Cetak Kembali

4.11. Display of Goods Data Report

Report All Item Data								Report Per Item Code																																																																																																															
<p>TOKO FARA COLLECTION Jl. Semarang - Purwodadi No.92, Waruk, Karangawen Kabupaten Demak Jawa Tengah</p> <p>LAPORAN DATA BARANG 04 Maret 2020</p> <table border="1"> <thead> <tr> <th>KODE BARANG</th> <th>NAMA BARANG</th> <th>KATEGORI</th> <th>GOLONGAN</th> <th>LOKASI</th> <th>HARGA BELI</th> <th>HARGA JUAL</th> <th>STOK</th> </tr> </thead> <tbody> <tr><td>SP-001</td><td>Trekkers Lampu - Putih</td><td>Sepatu</td><td>Anak</td><td>Rak - 1</td><td>80.000</td><td>104.000</td><td>16</td></tr> <tr><td>SP-002</td><td>Acilles BB - Navy</td><td>Sepatu</td><td>Dewasa</td><td>Rak - 1</td><td>100.000</td><td>130.000</td><td>5</td></tr> <tr><td>SP-003</td><td>Kanvas - Putih</td><td>Sepatu</td><td>Dewasa</td><td>Rak - 1</td><td>70.000</td><td>91.000</td><td>5</td></tr> <tr><td>SP-004</td><td>Rionella Chemo 02 - Hitam</td><td>Sepatu</td><td>Dewasa</td><td>Rak - 1</td><td>100.000</td><td>130.000</td><td>5</td></tr> <tr><td>SP-005</td><td>Trekkers Comic - Magenta</td><td>Sepatu</td><td>Dewasa</td><td>Rak - 1</td><td>70.000</td><td>91.000</td><td>5</td></tr> <tr><td>SD-001</td><td>Ando Kidd - Hitam</td><td>Sandal</td><td>Anak</td><td>Rak - 2</td><td>40.000</td><td>48.000</td><td>5</td></tr> <tr><td>SD-002</td><td>Homy ped SS - Hitam</td><td>Sandal</td><td>Anak</td><td>Rak - 2</td><td>100.000</td><td>120.000</td><td>5</td></tr> <tr><td>SD-003</td><td>Caril Juko M - Black</td><td>Sandal</td><td>Dewasa</td><td>Rak - 2</td><td>40.000</td><td>48.000</td><td>4</td></tr> <tr><td>SD-004</td><td>AOD Verona - BRK</td><td>Sandal</td><td>Dewasa</td><td>Rak - 2</td><td>80.000</td><td>96.000</td><td>5</td></tr> <tr><td>SD-005</td><td>Rutilief FFC 707 - Tan</td><td>Sandal</td><td>Dewasa</td><td>Rak - 2</td><td>90.000</td><td>108.000</td><td>5</td></tr> </tbody> </table>								KODE BARANG	NAMA BARANG	KATEGORI	GOLONGAN	LOKASI	HARGA BELI	HARGA JUAL	STOK	SP-001	Trekkers Lampu - Putih	Sepatu	Anak	Rak - 1	80.000	104.000	16	SP-002	Acilles BB - Navy	Sepatu	Dewasa	Rak - 1	100.000	130.000	5	SP-003	Kanvas - Putih	Sepatu	Dewasa	Rak - 1	70.000	91.000	5	SP-004	Rionella Chemo 02 - Hitam	Sepatu	Dewasa	Rak - 1	100.000	130.000	5	SP-005	Trekkers Comic - Magenta	Sepatu	Dewasa	Rak - 1	70.000	91.000	5	SD-001	Ando Kidd - Hitam	Sandal	Anak	Rak - 2	40.000	48.000	5	SD-002	Homy ped SS - Hitam	Sandal	Anak	Rak - 2	100.000	120.000	5	SD-003	Caril Juko M - Black	Sandal	Dewasa	Rak - 2	40.000	48.000	4	SD-004	AOD Verona - BRK	Sandal	Dewasa	Rak - 2	80.000	96.000	5	SD-005	Rutilief FFC 707 - Tan	Sandal	Dewasa	Rak - 2	90.000	108.000	5	<p>TOKO FARA COLLECTION Jl. Semarang - Purwodadi No.92, Waruk, Karangawen Kabupaten Demak Jawa Tengah</p> <p>LAPORAN DATA BARANG 04 Maret 2020</p> <table border="1"> <thead> <tr> <th>KODE BARANG</th> <th>NAMA BARANG</th> <th>KATEGORI</th> <th>GOLONGAN</th> <th>LOKASI</th> <th>HARGA BELI</th> <th>HARGA JUAL</th> <th>STOK</th> </tr> </thead> <tbody> <tr> <td>SP-001</td> <td>Trekkers Lampu - Putih</td> <td>Sepatu</td> <td>Anak</td> <td>Rak - 1</td> <td>80.000</td> <td>104.000</td> <td>16</td> </tr> </tbody> </table> <p>Pemeriksa (.....) Petugas (April)</p>								KODE BARANG	NAMA BARANG	KATEGORI	GOLONGAN	LOKASI	HARGA BELI	HARGA JUAL	STOK	SP-001	Trekkers Lampu - Putih	Sepatu	Anak	Rak - 1	80.000	104.000	16
KODE BARANG	NAMA BARANG	KATEGORI	GOLONGAN	LOKASI	HARGA BELI	HARGA JUAL	STOK																																																																																																																
SP-001	Trekkers Lampu - Putih	Sepatu	Anak	Rak - 1	80.000	104.000	16																																																																																																																
SP-002	Acilles BB - Navy	Sepatu	Dewasa	Rak - 1	100.000	130.000	5																																																																																																																
SP-003	Kanvas - Putih	Sepatu	Dewasa	Rak - 1	70.000	91.000	5																																																																																																																
SP-004	Rionella Chemo 02 - Hitam	Sepatu	Dewasa	Rak - 1	100.000	130.000	5																																																																																																																
SP-005	Trekkers Comic - Magenta	Sepatu	Dewasa	Rak - 1	70.000	91.000	5																																																																																																																
SD-001	Ando Kidd - Hitam	Sandal	Anak	Rak - 2	40.000	48.000	5																																																																																																																
SD-002	Homy ped SS - Hitam	Sandal	Anak	Rak - 2	100.000	120.000	5																																																																																																																
SD-003	Caril Juko M - Black	Sandal	Dewasa	Rak - 2	40.000	48.000	4																																																																																																																
SD-004	AOD Verona - BRK	Sandal	Dewasa	Rak - 2	80.000	96.000	5																																																																																																																
SD-005	Rutilief FFC 707 - Tan	Sandal	Dewasa	Rak - 2	90.000	108.000	5																																																																																																																
KODE BARANG	NAMA BARANG	KATEGORI	GOLONGAN	LOKASI	HARGA BELI	HARGA JUAL	STOK																																																																																																																
SP-001	Trekkers Lampu - Putih	Sepatu	Anak	Rak - 1	80.000	104.000	16																																																																																																																

4.12. User Data Report Display

TOKO FARA COLLECTION
 Jl. Semarang - Purwodadi No.92, Waruk, Karangawen
 Kabupaten Demak Jawa Tengah

LAPORAN DATA USER
 06 Desember 2019

KODE USER	NAMA USER	GRUP
01	Uwatun	Admin
02	lin	Pimpinan
03	April	Gudang

Pemeriksa (.....) Petugas (Uwatun)

4.13. Supplier Data Report Display

TOKO FARA COLLECTION Jl. Semarang – Purwodadi No.92, Waruk, Karangawen Kabupaten Demak Jawa Tengah			
LAPORAN DATA SUPPLIER			
04 Maret 2020			
KODE SUPPLIER	NAMA SUPPLIER	ALAMAT	NO TELPON
KS-001	Ahmad	Jl. Lingkar Barat Kudus	085606123454
KS-002	PT.AC Jaya	Jl. Ageng No 4 Kudus	082151666898
KS-003	Toko Sepatu Amy	Jl. Mulia Raya NO 98 Jakarta	086813221999
KS-004	Sinar	Jl.Kapuk No 6 Jakarta Utara	021555144775
KS-005	Maju	Jl Kembang Timur Semarang	087111287232
KS-006	PT.Wawas Shoes	Semarang Timur No 2	056987711111
KS-007	Kamilia Cemerlang	Jl.Iman Borjol Semarang	092133111987
KS-008	Monggo	Jl.Ageng Mulya Demak	085113242555
Pemeriksa		Petugas	
(.....)		(Uuwatun)	

4.14. Customer Data Report View

TOKO FARA COLLECTION Jl. Semarang – Purwodadi No.92, Waruk, Karangawen Kabupaten Demak Jawa Tengah			
LAPORAN DATA PELANGGAN			
04 Maret 2020			
KODE PELANGGAN	NAMA PELANGGAN	ALAMAT	NO TELPON
PL-001	Aisun	Karangawen	085601235282
PL-002	Ana Mariam	Karangawen	089999333447
PL-003	Ayu Dewi	Karangawen	082566878902
PL-004	Bayu Aji	Karangawen	085601245611
PL-005	Caca Mya	Mranggen	082787929008
PL-006	Daniel Yana	Topogawan	087667562343
PL-007	Karunia Amir	Mranggen	021777519832
PL-008	Salim	Semarang	085601122645
Pemeriksa		Petugas	
(.....)		(Uuwatun)	

4.15. Display Purchase Data Report Form

FARA COLLECTION

Laporan Data Pembelian

Menu ini digunakan untuk melihat data Pembelian

Mulai Tanggal:

Sampai Tanggal:

Cetak
Kembali

4.16. Report View Purchase Data Transactions

TOKO FARA COLLECTION Jl. Semarang – Purwodadi No.92, Waruk, Karangawen Kabupaten Demak Jawa Tengah									
LAPORAN PEMBELIAN									
Periode Tanggal : 01/01/2020 sampai 31/01/2020									
NO FAKTUR	TANGGAL	SUPPLIER	KODE BARANG	NAMA BARANG	HARGA	BANYAK	SUB TOTAL	USER	
1111	01/01/2020	Ahmad	SP-001	Trekkers Lampu - Putih	70.000	6	420.000	01	
1111	01/01/2020	Ahmad	SP-002	Jardies SS - Navy	100.000	6	600.000	01	
1122	01/01/2020	Kamilia Cemerlang	SP-003	Kanvas - Putih	70.000	6	420.000	01	
1122	01/01/2020	Kamilia Cemerlang	SP-004	Rionella Cerie 02 - Hitam	100.000	6	600.000	01	
1122	01/01/2020	Kamilia Cemerlang	SP-005	Trekkers Comic - Magenta	70.000	6	420.000	01	
TOTAL							30	2.460.000	
DEMAM, 08 Maret 2020									
Pemeriksa		Petugas							
(.....)		(Uuwatun)							

4.17. Sales Data Report Form Display

FARA COLLECTION

Laporan Data Penjualan



Menu ini digunakan untuk melihat data penjualan

Mulai Tanggal:

Sampai Tanggal:

Cetak
Kembali

4.18. Report View Sales Data Transactions

Report Sales Data Transactions								Selling Note																																																																		
 TOKO FARA COLLECTION Jl. Semarang – Purwodadi No.92, Waruk, Karangawen Kabupaten Demak Jawa Tengah								 TOKO FARA COLLECTION Jl. Semarang – Purwodadi No.92, Waruk, Karangawen Kabupaten Demak Jawa Tengah																																																																		
LAPORAN PENJUALAN								NOTA PENJUALAN																																																																		
Periode Tanggal : 01/01/2020 sampai 31/01/2020								No Nota : NT000001 Kode Pelanggan : PL-001 Alamat : Karangawen																																																																		
<table border="1"> <thead> <tr> <th>NOTA</th> <th>TANGGAL</th> <th>PELANGGAN</th> <th>KODE BARANG</th> <th>NAMA BARANG</th> <th>HARGA</th> <th>BANYAK</th> <th>SUB TOTAL</th> <th>USER</th> </tr> </thead> <tbody> <tr> <td>NT000001</td> <td>02/01/2020</td> <td>Alimun</td> <td>SP-001</td> <td>Trekkers Lampu - Putih</td> <td>91.000</td> <td>4</td> <td>364.000</td> <td>01</td> </tr> <tr> <td>NT000002</td> <td>03/01/2020</td> <td>Ana Mariam</td> <td>SP-002</td> <td>Ardiles BB - Navy</td> <td>130.000</td> <td>1</td> <td>130.000</td> <td>01</td> </tr> <tr> <td>NT000003</td> <td>04/01/2020</td> <td>Ayu Dewi</td> <td>SP-003</td> <td>Kanvas - Putih</td> <td>91.000</td> <td>1</td> <td>91.000</td> <td>01</td> </tr> <tr> <td>NT000003</td> <td>04/01/2020</td> <td>Ayu Dewi</td> <td>SP-004</td> <td>Rionella Chene 02 - Hitam</td> <td>130.000</td> <td>1</td> <td>130.000</td> <td>01</td> </tr> <tr> <td>NT000003</td> <td>04/01/2020</td> <td>Ayu Dewi</td> <td>SP-005</td> <td>Trekkers Comic - Magenta</td> <td>91.000</td> <td>1</td> <td>91.000</td> <td>01</td> </tr> <tr> <td colspan="6">TOTAL</td> <td>8</td> <td>806.000</td> <td></td> </tr> </tbody> </table>								NOTA	TANGGAL	PELANGGAN	KODE BARANG	NAMA BARANG	HARGA	BANYAK	SUB TOTAL	USER	NT000001	02/01/2020	Alimun	SP-001	Trekkers Lampu - Putih	91.000	4	364.000	01	NT000002	03/01/2020	Ana Mariam	SP-002	Ardiles BB - Navy	130.000	1	130.000	01	NT000003	04/01/2020	Ayu Dewi	SP-003	Kanvas - Putih	91.000	1	91.000	01	NT000003	04/01/2020	Ayu Dewi	SP-004	Rionella Chene 02 - Hitam	130.000	1	130.000	01	NT000003	04/01/2020	Ayu Dewi	SP-005	Trekkers Comic - Magenta	91.000	1	91.000	01	TOTAL						8	806.000		Tanggal : 02/01/2020 Nama Pelanggan : Alimun No Telp : 085601229282 Kasir : Uswatun			
NOTA	TANGGAL	PELANGGAN	KODE BARANG	NAMA BARANG	HARGA	BANYAK	SUB TOTAL	USER																																																																		
NT000001	02/01/2020	Alimun	SP-001	Trekkers Lampu - Putih	91.000	4	364.000	01																																																																		
NT000002	03/01/2020	Ana Mariam	SP-002	Ardiles BB - Navy	130.000	1	130.000	01																																																																		
NT000003	04/01/2020	Ayu Dewi	SP-003	Kanvas - Putih	91.000	1	91.000	01																																																																		
NT000003	04/01/2020	Ayu Dewi	SP-004	Rionella Chene 02 - Hitam	130.000	1	130.000	01																																																																		
NT000003	04/01/2020	Ayu Dewi	SP-005	Trekkers Comic - Magenta	91.000	1	91.000	01																																																																		
TOTAL						8	806.000																																																																			
								<table border="1"> <thead> <tr> <th>KODE BARANG</th> <th>NAMA BARANG</th> <th>HARGA</th> <th>BANYAK</th> <th>SUB TOTAL</th> </tr> </thead> <tbody> <tr> <td>SP-001</td> <td>Trekkers Lampu - Putih</td> <td>Rp91.000</td> <td>4</td> <td>Rp364.000</td> </tr> <tr> <td colspan="4"></td> <td>Total</td> <td>Rp806.000</td> </tr> <tr> <td colspan="4"></td> <td>Bayar</td> <td>Rp365.000</td> </tr> <tr> <td colspan="4"></td> <td>Sisa</td> <td>Rp1.000</td> </tr> </tbody> </table>				KODE BARANG	NAMA BARANG	HARGA	BANYAK	SUB TOTAL	SP-001	Trekkers Lampu - Putih	Rp91.000	4	Rp364.000					Total	Rp806.000					Bayar	Rp365.000					Sisa	Rp1.000																																			
KODE BARANG	NAMA BARANG	HARGA	BANYAK	SUB TOTAL																																																																						
SP-001	Trekkers Lampu - Putih	Rp91.000	4	Rp364.000																																																																						
				Total	Rp806.000																																																																					
				Bayar	Rp365.000																																																																					
				Sisa	Rp1.000																																																																					
Pemeriksa								Petugas																																																																		
(.....)								(Uswatun)																																																																		



4.19. Minimum Stock Report Form for Items

FARA COLLECTION
Laporan Data Stok Minimal
 Menu ini digunakan untuk melihat data Stok Minimal

Nama Barang

Kode Barang

4.20. Minimal Stock Report Display Goods

Report All Minimum Stock Items				Report Per Minimum Stock Code for Items																							
 TOKO FARA COLLECTION Jl. Semarang – Purwodadi No.92, Waruk, Karangawen Kabupaten Demak Jawa Tengah				 TOKO FARA COLLECTION Jl. Semarang – Purwodadi No.92, Waruk, Karangawen Kabupaten Demak Jawa Tengah																							
LAPORAN STOK MINIMAL				LAPORAN STOK MINIMAL																							
10 Maret 2020				10 Maret 2020																							
<table border="1"> <thead> <tr> <th>KODE BARANG</th> <th>NAMA BARANG</th> <th>STOK MINIMAL</th> <th>STOK SEKARANG</th> </tr> </thead> <tbody> <tr> <td>SP-001</td> <td>Trekkers Lampu - Putih</td> <td>2</td> <td>0</td> </tr> <tr> <td>SD-005</td> <td>Rulief FFC 707 - Tan</td> <td>2</td> <td>0</td> </tr> </tbody> </table>				KODE BARANG	NAMA BARANG	STOK MINIMAL	STOK SEKARANG	SP-001	Trekkers Lampu - Putih	2	0	SD-005	Rulief FFC 707 - Tan	2	0	<table border="1"> <thead> <tr> <th>KODE BARANG</th> <th>NAMA BARANG</th> <th>STOK MINIMAL</th> <th>STOK SEKARANG</th> </tr> </thead> <tbody> <tr> <td>SP-001</td> <td>Trekkers Lampu - Putih</td> <td>2</td> <td>0</td> </tr> </tbody> </table>				KODE BARANG	NAMA BARANG	STOK MINIMAL	STOK SEKARANG	SP-001	Trekkers Lampu - Putih	2	0
KODE BARANG	NAMA BARANG	STOK MINIMAL	STOK SEKARANG																								
SP-001	Trekkers Lampu - Putih	2	0																								
SD-005	Rulief FFC 707 - Tan	2	0																								
KODE BARANG	NAMA BARANG	STOK MINIMAL	STOK SEKARANG																								
SP-001	Trekkers Lampu - Putih	2	0																								
Pemeriksa				Petugas																							
(.....)				(April)																							

4.21. Report Form Display LIFO Inventory

FARA COLLECTION
Laporan Data Persediaan LIFO
 Menu ini digunakan untuk melihat data persediaan

Nama Barang

Kode Barang

4.2.2. Report Form Display LIFO Inventory

TOKO FARA COLLECTION <small>Jl. Semarang – Purwodadi No.92, Waruk, Karangawen Kabupaten Demak Jawa Tengah</small>							
KARTU PERSEDIAAN LIFO							
Tanggal	: 10 Maret 2020						
Kode Barang	: SP-001						
Nama Barang	: Trekkers Lampu - Putih						
Stok Akhir	: 12						
TANGGAL	KETERANGAN	MASUK	HARGA BELI	KELUAR	HARGA JUAL	JUMLAH	TGL BELI
01/01/2020	Ahmad	8	70.000	0	0	8	
02/01/2020	Aimun	0	0	4	91.000	2	01/01/2020
01/02/2020	Ahmad	12	80.000	0	0	14	
14/02/2020	Bayu Aji	0	0	2	104.000	12	01/02/2020
Pemeriksa				Petugas			
(.....)				(April)			

5. CONCLUSION

- 5.1. There is a trial validation carried out by experts *internal* and user (*user*) so can help product made writer become more Good with suggestions for improvement provided .
- 5.2. There is a system information supply computerized goods , *users* more easy do activity recording transaction purchase goods and expenses goods as well as For know minimum stock of goods Because all over transaction saved and connected in One *databases* as well as be equipped with security right access For a number of interested *users* use system This .
- 5.3. There is planning information supply item , user will more fast and easy in do printing report supply goods with results accurate so that can minimize time recording and errors recording .

BIBLIOGRAPHY

- Ahmad, Yani, 2015; "*Lifo Fifo Desktop Application (Case Study: KFC Warehouse in Margomulyo)*" , Vol.5, No.3, 2015, 90-107. Surabaya: Narotama University Surabaya.
- Al Fatta, Hanif, 2017; "*Information Systems Analysis and Design for Competitive Advantage of Modern Companies and Organizations*" , Yogyakarta: ANDI .
- Ariesto Hadi Sutopo and Adrianus Arief, 2010; "*Skilled in Processing Qualitative Data*" , Jakarta: Prenada Media Group.
- Atyanto Mahatmyo, 2016; "*Accounting Information Systems An Introduction*" , Yogyakarta: Deepublish.
- Budhi Irawan, 2005 ; "*Computer Networks*" , 1st Edition , Yogyakarta : Graha I Science .

- Borg, Walter R., & Gall, M.D., 1983; " *Educational Revised Edition* ", Yogyakarta: Andi.
- Edy Irwansyah and Jurike V. Moniaga, 2014; " *Introduction to Information Technology* " , Yogyakarta : Deepublish.
- Ervan Erzha, 2014; " *Smart Book for Assembling Computers: Smart Book for Hobbies and Business* " , Jakarta: Indonesian Sky Sheet.
- Fathansyah, 2015; " *Database* " , Bandung: Informatics Bandung.
- Fauzi and Amin, Miftakul H, 2012; " *Visual Basic and SQL Server 2000 Database Programming* " , Yogyakarta: CV. Andi Offset.
- Fransisca Natalia and Cristine Janani, 2018; " *Designing an Accounting Information System for Inventory of Goods Using the Lifo Method on Sutra Fashion Johar* " , Vol.7, No.2, 2018, 94-105. Bekasi: Bima Sarana Informatics University.
- Hermanwan, Sigit, 2008; " *Manufacturing Company Accounting* " , Yogyakarta: Graha Ilmu.
- Jeperson, Hutahaean, 2015; " *Information System Concepts* " , Yogyakarta: Deepublish.
- Jogiyanto HM, 2011; " *Information Technology Systems* " , Yogyakarta: Andi.
- Kadir, Abdul, 2014; " *Introduction to Information Systems Revised Edition* " , Yogyakarta: Andi.
- Krismiaji, 2015; " *Accounting Information Systems* " , Yogyakarta: Publishing Unit. Yogyakarta. : CV Andi Offset.
- Mahatmyo, Atyanto, 2014; " *Accounting Information Systems An Introduction* " , Yogyakarta: Deepublish.
- Oetomo, Sutedjo Dharma, 2003; " *Popular Terminology of Information Systems* " , Yogyakarta: Graha Ilmu.
- Stefano, 2014 ; " *How to Build an Information System Using VB.Net and Dxprience Components* " , Yogyakarta: CV. Andi Offset.
- Sugiono, Arief, 2009; " *Basic Practical Guide to Financial Report Analysis* " , PT. Grasindo : Jakarta.
- Suryantara, I Gusti Ngurah, 2014; " *Designing Accounting Applications with VB.Net* " , Jakarta: PT Elex Media Komputindo.
- Jacob, 2012; " *Introduction to Information Systems* " , Yogyakarta: Graha Ilmu.
- Yulia and Dewi Pratita, 2015; " *Management Information Systems Teaching Materials* " , Yogyakarta: Deepublish.